



FEATURES

- ▶ 11" Depth, 1.5" Height (280mm, 38mm)
- ▶ 91% Efficient*
- ▶ RoHS & WEEE Compliant
- ▶ N+1 Redundant
- ▶ Three Modules per 1U Shelf
- ▶ I2C EEPROM
- ▶ Competitively Priced and Low Cost of Ownership
- ▶ Outline Dimensions: Meets EIA310D

PRODUCT OVERVIEW

The Signature 1000-watt Universal Input modules are high-reliability rectifier/battery chargers for TelCom applications (-54VDC) or Front Ends (+48VDC) in distributed power architectures. Other outputs from 42 to 58VDC are available on special order. The modules use 21st century conversion technology to achieve 91% efficiency* and their compact size.

They accept remote program controller commands and report performance and fault conditions.

The matching 1U power shelf features a depth of just 359mm. It hosts three modules and is capable of delivering up to 3000 watts to the common load. Alternatively, the shelf can deliver 2000 watts of redundant power. The user may provide AC power to the shelf from a single phase or a balanced three-phase source.

TDI offers tailored versions of the modules and shelves to meet your particular needs.

SPECIFICATIONS

INPUT

Input Voltage: 90-265 VAC, 1Ø, 47-63 Hz.

Input Current: 15A RMS maximum at low line, full load.

Inrush Current: 45A peak, cold and hot turn-on.

Hold-up time: 20mSec. minimum.

***Efficiency:** 91% typical at 230 VAC, 75 to 100% load.

Conducted Emissions: FCC Part 15, Sub-part J, Class A; and EN55022, Class A; Meets class B when installed in matching power shelf

OUTPUT

Total Power: 1000 Watts continuous.

Output: ±(42 to 58)VDC Contact factory for other voltages.

Current Sharing: Slope Programming.

Ripple, Noise: ≤1% P-P measured @ 20MHz bandwidth.

Line Regulation: ±0.25% maximum.

Load Regulation: ±2.0% maximum from center load to full or zero load.

Turn On Delay: ≤1 Second

Turn On Overshoot: ≤1%

Temperature Coefficient: =0.02% / °C

Dynamic Response: Return to regulation ≤500µS. Peak excursion ≤3% for a 50-100% step load change.

PROTECTION

Over-voltage: Latching type. Shut-down occurs at 110 to 120% of voltage set point. Recycle AC input.

Short Circuit: Auto-recovery.

Over-current: Foldback. 110-130%. Auto-recovery.

Over-temperature: Internal thermostat. Auto-recovery.

Input Over-current: Internal fusing on both AC legs.

VISUAL ALARMS

Summary Fault: An amber LED illuminates when the output voltage falls 10% below set point.

Power Good: A green LED is illuminated when the AC input is within operating range..

ELECTRONIC ALARMS

AC Fail: Active low signal asserts 5mSec prior to loss of regulation due to loss, reduction of input power. Over-temperature: Active low signal when over-temperature protection shutdown is within 5°C.

DC Under Voltage: Active low signal when output falls below 10% of nominal voltage.

Isolated Output Low: Isolated open collector signal, via an optoisolator, from AC input and DC output. High impedance signal when output is below 10% of set point, 5mA sink capability.

SPECIFICATIONS

I²C EEPROM

Microchip to store and access part number, revision, date code, etc. Customer may define and provide software for downloading..

EXTERNAL CONTROLS

Remote Inhibit: Application of TTL low or contact closure will cause duty cycle to close and a DC Under Voltage alarm to be issued.

PS On: Application of TTL low or contact closure will enable module. Short Pin.

Voltage Programming: Output adjustable +4 to -16V. Programming input 0-5VDC, 4V/V

ENVIRONMENTAL

Temperature:

Normal Operation: -20°C to 55°C full ratings.

High Temp. Operation: Derate 55oC to 70oC. Contact factory for details.

Low Temp. Turn-on: -20° to 0°C, 5-minute warm up.

Storage: -40°C to +85°C

Temp. Coefficient: =0.02%/°C

Altitude, Operating: No deration to 10,000 feet

Humidity: 0-95%, non-condensing, 10°-50°C. Vibration, Operating: Test 3, Office Vibration, Bellcore NEBS.

***Vibration, Transport: 5-100Hz, 0.5g.@ 0.1 octaves/min.**

***Shock, Transport: Packaged, 30g, half sine, 18ms, 1 drop each on 6 faces**

***Contact factory for details.**

PACKAGING AND COOLING

Cooling: Internal fan cooling. Optional fan speed control. Physical

Dimensions: See below.

Weight: 3.96lbs (1.80Kg)

WARRANTY

Two years from date of original shipment.

SAFETY & EMC COMPLIANCE

cULus to UL 60950-1 CB Report and Certificate to EN 60950-1

CE Marking: Low Voltage Directive, 'Component Power Supplies'

Harmonics: EN 61000-3-2

Static Discharge: EN 61000-4-2, '95 Level 3, stand-alone.

RF Field Susceptibility: EN61000-4-3

Fast Transients/Burst: EN61000-4-4, Level 3

Surge Susceptibility: EN61000-4-5, Level 4, 4kV

CONNECTOR INTERFACE

INPUT, OUTPUT, AUXILIARY FUNCTIONS:

Module Connector: FCI P/N 51935-002

Mate: FCI P/N 51936-001, 51915-016 or equivalents.

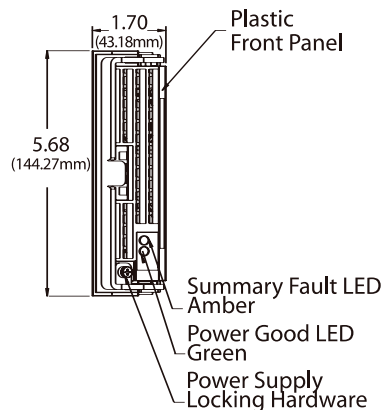
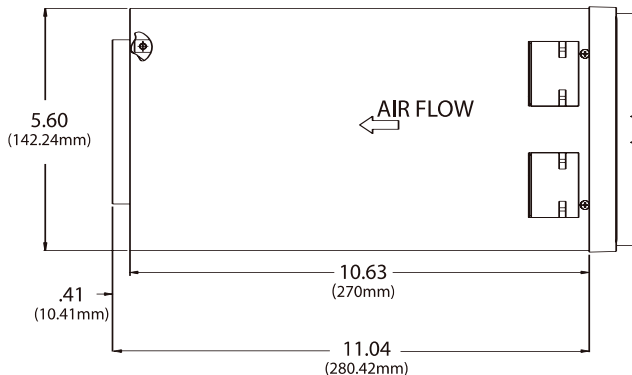

Connector J1

J1 - P1 = RTN

J1 - P2 = TRN

J1 - P3 = RTN

J1 - P4 = -54VDC OUT

J1 - P5 = -54VDC OUT

J1 - P6 = -54VDC OUT

J1 - P7 = SAFETY GROUND

J1 - P8 = AC NEUTRAL

J1 - P9 = AC LINE

J1 - A2 = +SENSE

J1 - A3 = ADDRESS A0

J1 - A4 = ADDRESS A1

J1 - A5 = ISOLATED DC_UV HI

J1 - B2 = WRITE PROTECT

J1 - B3 = -SENSE

J1 - B4 = ISOLATED DC_UV LOW

J1 - B5 = OVER TEMP WARNING

J1 - C2 = SIGNAL GND

J1 - C3 = SDA

J1 - C4 = SCL

J1 - C5 = DC_UV

J1 - D2 = PS_ON

J1 - D3 = AC FAIL

J1 - D4 = INHIBIT

J1 - D5 = PROGRAM VOLTAGE