

OVERVIEW

The 2700W Environmentally Sealed Power Module (ESPM) is free air convection cooled and is NEMA rated to be watertight, submersible, dusttight, corrosion resistant and sleet resistant in hazardous locations.

Designed for outdoor or indoor applications, the ESPM can be exposed directly to a variety of harsh environments. A sunshade is recommended if subjected to the sun's rays.

The ESPM 2700W module is oil filled to conduct internal heat to the finned aluminum chassis and the outside ambient air. The internal components stay cool and reliable. Other features include:

- Immersion Protection per IP-67
- Free Air Convection Cooled
- Over 90% Efficient*
- 100% HASS Tested
- Optional CANopen Monitoring and Control

The ESPM modules are well suited for telecommunications, industrial, off-shore platforms, mobile and other harsh environments that require highly reliable DC power.

SPECIFICATIONS

INPUT SPECIFICATIONS

Continuous Operating Voltage: 185 to 275VAC 47 – 63 Hz @ 0.99PF typical

Input Current: 18A RMS maximum at 176VAC

Inrush Current: 45A Peak

OUTPUT SPECIFICATIONS

Output: -54VDC @ 0 – 50A (2700 Watts maximum)

***Efficiency:** >90% at 230VAC input, 50 to 100% load

Line Regulation: Less than +/- 0.25%

Load Regulation: 1 volt Droop Current Sharing for N+1 parallel redundant operation

Remote Sensing: Remote sense leads available to compensate for load connection IR drop

Dynamic Response: <5% for a 50 to 100% step load. Return to regulation in < 500uSec

Ripple & Noise: <1% P-P measured with 20 MHz bandwidth

Temperature coefficient: < 0.02% /°C

Hold Up Time: 10 mSec minimum from loss of AC input (16 mSec until output drops to 42V)

Turn-on delay: <2 seconds

Turn-on Overshoot: <1% of nominal output voltage

PROTECTION

Output Over-voltage: Shutdown <120% of nominal output voltage, recycle input voltage to reset OVP

Output Over-current / Short Circuit Protection: Electronic with automatic recovery

Over-temperature: Over-temperature shutdown with automatic recovery

Input Over-current: AC fused internally

EXTERNAL CONTROL

Power Plant Controller: Units compatible with TDI Signature and ICON Power System controllers

Remote Inhibit: TTL control signal or contact closure will cause module output to shutdown

AC Fail: AC OK, TTL compatible alarm

Output Good: Output Good, TTL compatible alarm

Voltage Programming: Output voltage may be programmed by 0 – 5V input at the rate of 4V/1V (consult factory)

ENVIRONMENTAL SPECIFICATIONS

Operating Environment: Hazardous location requirements: Division 2, Zone 2

Immersion Protection per IP-67 (Sealed against dust, total liquid immersion to 1 meter depth for 30 minutes)

Temperature Normal Operation: 0 to + 55°C. Guaranteed startup to –40°C. Continuous operation from –30 to +55°C after 30-minute warm up

High Temperature Operation: to 70°C with de-rating (consult Factory for details)

Storage: -50 to +85°C

Altitude, Operating: No power derating to 10,000 Feet

Humidity: 1 to 100% condensing

Vibration, Operating: 14g-RMS, random, tri-axial vibration for 1 hour

Vibration, Transportation: Packaged units will withstand, without damage, two complete cycles: 5Hz to 100Hz to 5Hz: 0.5g at 0.1 octaves/minute; 100Hz to 500Hz to 100Hz, 1.6g at 0.25 octaves/minute

Shock, Transport: Packaged, 30" drops, 6 faces, 8 corners

Salt Fog: MIL-STD 810C, Method 509.1

Audible Noise: None

SAFETY AND REGULATORY SPECIFICATIONS

Input Leakage: Current to ground < 3.5mA at 250VAC

Input to Ground Isolation: 1500VAC

Input to Output Isolation: 3000VAC

Output to Ground Isolation: 500VAC

Markings: UL, CE Pending

ENVIRONMENTAL STANDARDS

UL60079-1: Electrical Apparatus for Explosive Gas Atmospheres

UL1604: Non-incendive electrical equipment for use in Class I Division 2 Hazardous Locations. Equivalent to FM Approvals Standard Class Number 3611

CAN/CSA-E60079-15:02: Electrical apparatus for explosive gas atmosphere, Part 15; Type of Protection "n"

EN50021:1999: European Norms (ATEX)

ELECTRO-MAGNETIC COMPATIBILITY

Conducted and Radiated Emissions: FCC Part 15, Sub-part j, Class A; and EN55022, Class A

Harmonics: EN 61000-3-2

Static Discharge: EN61000-4-2, Class 3, stand-alone

RF Field Susceptibility: EN61000-4-3, Class 3

Fast Transient/Burst: EN61000-4-4, Class 3 (2kV)

Surge: EN61000-4-5, Class 4 (2kV L-L, 4kV L-EARTH) (Units tested to 8kV surge L-L and L-EARTH)

PACKAGING AND COOLING

Cooling: Natural convection cooling. No fans or blowers required

Dimensions: H7.70" (19.56cm) x W8.60" (21.84cm) x D15.50" (39.37cm)

Weight: 32.5 Pounds (14.74 kg)

INPUT AND OUTPUT OPTIONS

(1) **Permanently tethered cables:** AC input and DC output, signals and controls

(2) **Terminal blocks** in permanently attached junction box

(3) **Hermetically sealed connectors:** AC input and DC output

LIMITED WARRANTY

Coverage: 2 years, Parts and Labor

OUTLINE

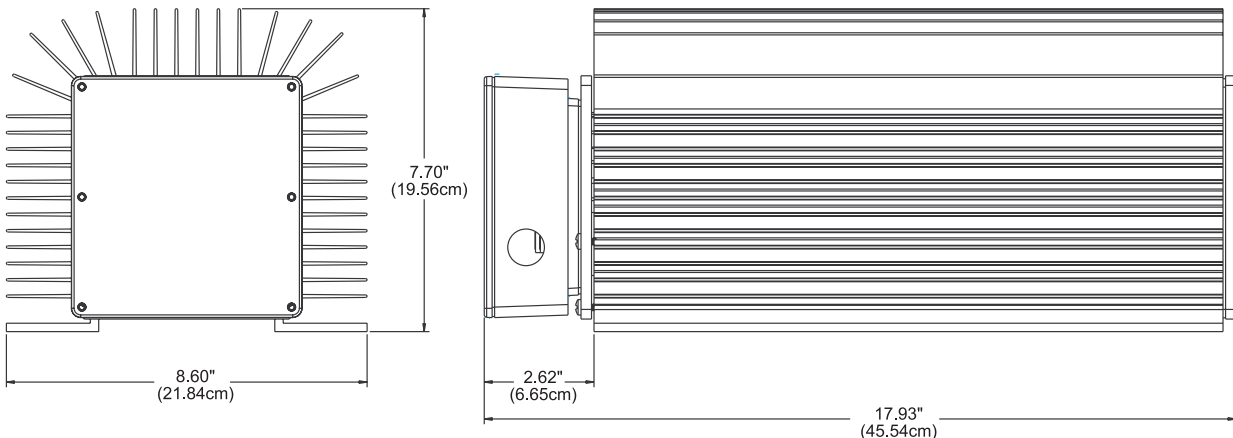

© Copyright 2007, Transistor Devices, Inc.

This document is believed to be correct at time of publication and Transistor Devices, Inc. accepts no responsibility for consequences from printing errors or inaccuracies. Specifications are subject to change without notice.

ESPM2700-r5-2/8/07